

StormForceTM

From Wavin

SURFACE WATER
DESIGN, SUPPLY
& INSTALLATION
— SORTED.



An Orbia business.

wavin.co.uk

“

StormForce really does deliver. One source supply and surface water management is totally sorted, so we can get on with the build.

It's fast, compliant, sustainable and top quality – what more could you want?”

Stewart McKechnie
Site Agent, Nationwide Engineering



StormForce™

Delivering expertise at every level

StormForce is the service that developers, tier one design and build contractors and civil engineering firms have been waiting for.

A high quality, single source solution to the design, supply and installation of surface water tanks and all their associated infrastructure, from capture and attenuation to dispersal.

End to end, everything is taken care of by Wavin – we consult and advise on site, we value engineer the optimum design, we manufacture and co-ordinate the required products and components, we install through fully trained StormForce partners, and we underpin the installation with a five-year warranty.

With one turnkey solution, and without managing multiple companies, you unlock the very best in surface water management, de-risking the construction of essential infrastructure and getting it in the ground faster, to your schedule and our high standards.

It's the future of sustainable drainage. It's fast and efficient. It's hassle and risk free, and it's quality and compliance assured. It's StormForce, and it's one less thing for you to worry about on every project you undertake.





1 CONSULT AND ADVISE

Surveying the site, assessing requirements and discussing project plans form the foundation of seamless delivery. We can undertake feasibility checks, identify and resolve site specific issues and ensure everyone is alive to current statutory and environmental regulation and best practice.

By anticipating problems, bringing our water management expertise to the table, and understanding your timescales, we can smooth progress, sustain scheduling and reduce costs.



2 DESIGN

To help manage water responsibly, there is nobody better placed to design the optimum solution than Wavin's Technical Team.

Harnessing our accumulated expertise, our product knowledge, our own technical tools and industry leading BIM packages, we can help you realise valuable efficiencies. With errors designed out in planning and modelling, installation is made easier, faster and, as far as is possible, error free.



StormForce™

Surface water design, supply & installation – sorted.

3 MANUFACTURE

With a 60-year plus pedigree, Wavin is a global leader in the supply of plastic pipe systems and the engineering of superior surface water solutions for the residential, commercial and industrial built environment.

From geocellular attenuation and infiltration tanks, gullies, inspection chambers, below ground pipework and vortex valves – across leading brands such as Osma, TwinWall, and AquaCell, we deliver higher performance and regulatory compliance and lower lifetime costs.

6 HANDOVER AND WARRANTY

StormForce continues to deliver beyond the installation phase. You can have total confidence in the quality of every delivered contract, underpinned by BBA-approved products and a 5-year warranty on the installation itself.



5 INSTALLATION

StormForce sees Wavin extend our manufacturing expertise to a supply and fit solution, designed to deliver our renowned quality at every touchpoint.

Working exclusively with accredited partners, our installer teams will be a seamless extension of Wavin, fully trained in Wavin products to deliver on site, on time and on budget. And, because every team is fully immersed in every aspect of Wavin's surface water solutions, installation is faster, more efficient and right first time.



4 SUPPLY

StormForce is one seamless, end-to-end solution, freeing you from the pain of co-ordinating multiple providers and the hassle of scheduling orders, deliveries, on-site storage and skilled labour.

Every detail is managed by Wavin under a single contract. We co-ordinate with our subcontractor and deliver everything required (our own products plus associated components such as membranes and geotextiles) for 'just-in-time' installation.



End-to-end quality

Any surface water system is only as good as the products it uses and, in choosing Wavin, you know you're guaranteeing performance, compliance, innovative engineering and assured quality. From rainwater collection and treatment to storage, release and transportation, installing Wavin solutions from end to end ensures a seamless build process and fault-free performance throughout the system's life.

Inspection Chambers

For adoptable and non-adoptable applications across the widest range of site situations, our fully certified range of chambers enable safe and easy inspection and maintenance access.

AquaCell NG

The AquaCell NG system equips contractors, civil engineers and installers with a powerful new advance in the construction of surface water management tanks. Manufactured in the UK from 100% recycled and recyclable plastic, it represents the future of sustainable drainage.

AquaCell

With the entire range now made from recycled material, AquaCell systems are the ultimate modular surface water management solution from landscaped to heavily trafficked areas – sustainable, lightweight, easy to handle and high capacity.

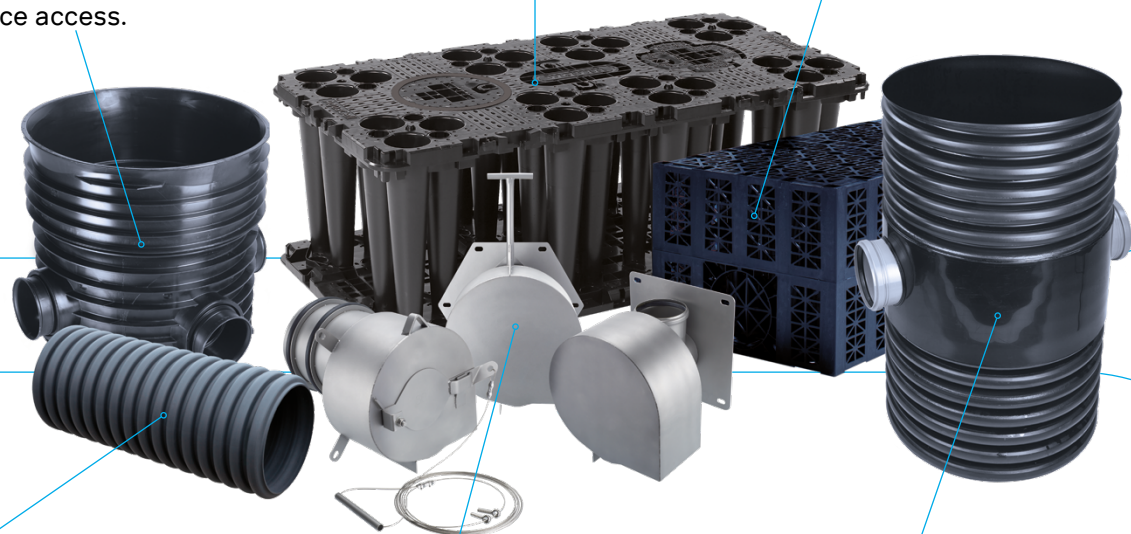

TwinWall

Trusted by professionals for its winning combination of strength and lightness, TwinWall's corrugated outer walls combine with a smooth inner to aid hydraulic flow.

Vortex Valves

Working in partnership with Mosbaek A/S, the first company to harness the vortex principle as a water brake, we individually engineer each valve in stainless steel to deliver the optimum flow control – whatever the site requirements.

Silt Traps

Proven in thousands of installations, our range of silt traps perform an essential function, effectively removing silt and sand from rainwater before it enters the storage or soakaway tank.

StormForce™ from Wavin. It adds up to more.

Join forces and win

- A total surface water management solution from rainfall collection to dispersal
- Single source supply saves the time and effort of co-ordinating providers
- In the ground faster and more efficiently, to your schedule
- Identify and resolve any site issues upfront
- The very best technical solutions, optimised by our design and installation teams
- Assured compliance and site suitability
- High performance and innovative brand leading products
- Known project costs and delivery schedules
- Just-in-time delivery for installation
- 5-year installation warranty
- The sustainable and cost-effective solution to managing responsibility for water resources and the environment.



StormForce™

From Wavin



The single-source surface water management solution



Wavin is part of Orbia, a community of companies working together to tackle some of the world's most complex challenges. We are bound by a common purpose: To Advance Life Around the World.

Orbia's Building and Infrastructure business Wavin is an innovative solutions provider for the global building and infrastructure industry. Backed by more than 60 years of product development experience, Wavin is advancing life around the world by building healthy, sustainable environments for global citizens. Whether it's to improve the distribution of clean drinking water, to make sanitation accessible for everyone, to create climate resilient cities, or to design comfortable living spaces, Wavin collaborates with municipal leaders, engineers, contractors, and installers to help future-proof communities, buildings and homes. Wavin has 12,000+ employees around 65 production sites worldwide, serving over 80 countries through a global sales and distribution network.

Wavin Limited | Edlington Lane | Doncaster | DN12 1BY
Tel. 0800 038 0088 | Web. www.wavin.co.uk | E-mail info@wavin.co.uk

© 2025 Wavin Wavin reserves the right to make alterations without prior notice. Due to continuous product development, changes in technical specifications may change. Installation must comply with the installation instructions.